



Best/Flex® Gravity Expandable Conveyor **Operation, Maintenance and Parts Manual**

B/FR



LongReach Telescopic Conveyors Pty Ltd

6 Capelli Road

Wingfield SA 5013

Tel: +61 (8) 8349 4777

Fax: +61 (8) 8349 5770

Email: service@longreach.au.com

Web: www.longreach.au.com

Free call (Australia only)

1800 819 139

CONTENTS

1	DOCUMENT CONTROL	3
2	IMPORTANT NOTES.....	3
3	WARRANTY.....	4
4	DESIGNATED USE.....	4
5	SPECIFICATIONS.....	4
6	INSPECTION AND MAINTENANCE	5
6.1	Maintenance Schedule	5
7	SAFETY	5
7.1	Preliminary Remarks	5
7.2	General Information	5
8	INSTALLATION	6
8.1	Shipping, Handling and Storage	6
8.2	Installation and unpacking	6
9	CONVEYOR OPERATION.....	7
9.1	Pre Operational Checks.....	7
9.2	Conveyor operation – Expansion and Compaction	7
9.3	Conveyor operation – Height Adjustment	8
9.4	Loading and unloading	8
9.5	Troubleshooting	9
10	SPARE PARTS	10
10.1	B/FR PARTS DIAGRAM.....	10
10.2	B/FR List.....	11
11	OPTIONAL EXTRAS.....	12
11.1	Package Stop Assembly.....	12
11.2	Leg Connect Assembly	13

1 DOCUMENT CONTROL

Document: BestFlex BFR Product Manual

Version: 1.1, Dated 29 October, 2008

Original By: K Hulleman

Revised By:

2 IMPORTANT NOTES

Please note the safety and warning notes in this publication.



Dangerous Situation

Could result in slight or minor injuries.



Damaging situation

Could result in damage to equipment or operating environment.



Operating hints and useful information.

• Indicates a list of important points

1. Indicates a list of important steps

BOLD Indicates a important notation

TEXT

Close adherence to the operating instructions is the prerequisite for fault-free operation and fulfilment of any rights to claim under guarantee. Please start by reading the operating instructions prior to operating the conveyor.

Keep operating instructions in the vicinity of the conveyor since it contains important information on service procedures.

3 WARRANTY

Your Best conveyor is protected by our premier warranty. LongReach Conveyors will replace, free of charge, parts that are damaged during the course of normal operation due to material or workmanship defects. This warranty extends for a period of one (1) year on all mechanical components.

This warranty does not cover damage due to accident, misuse, abuse and negligence. This warranty does not cover damage due to improper operation or maintenance, connection to improper voltage supply, or attempted repair/modification by anyone other than authorized LongReach Conveyors service personnel.

4 DESIGNATED USE

This BestFlex Conveyor is intended for industrial use. The design and manufacture of the equipment corresponds to the applicable standards and regulations. The maximum unit load of a product under normal operation is outlined in the specifications section of this manual.

5 SPECIFICATIONS

Your Best/Flex gravity conveyor is built according to the following standard specifications:

	B/FR SERIES
CONVEYOR BED WIDTH	
Inches	18, 24, 30
mm	457, 610, 762
LOAD CAPACITY – per lineal ft (305mm)	
Pounds (LBS)	145
Kilograms (Kg)	74
ROLLERS	
Diametre mm	35
Bearings	Precision
CASTORS	
Inches	5 x 1 ¼
mm	127 x 32
ADJUSTABLE CONVEYOR HEIGHT	
Inches	30 to 42 ½
mm	762 to 1080
EXPANSION TO COMPACTION RATIOS	
5" (127mm) axle centre	3.3:1
4" (102mm) axle centre	2.7:1
3" (76mm) axle centre	2.0:1

6 INSPECTION AND MAINTENANCE

6.1 Maintenance Schedule

Your Best/Flex conveyor is designed to be virtually maintenance free. We do recommend that you regularly inspect the unit to ensure proper operation of mechanical and safety systems.

DAILY:

- Keep your BestFlex conveyor free of dirt, debris and grease accumulation
- Inspect leg elevations and adjust as necessary to ensure smooth product flow
- Look for mechanical damage or worn components and replace as necessary

MONTHLY:

- Check to ensure all nuts and bolts are moderately tight

NOTE: DO NOT OVER TIGHTEN AS THIS MAY CAUSE FRAME DISTORTION AND PREVENT THE SYSTEM FROM PROPERLY FLEXING.

7 SAFETY

7.1 Preliminary Remarks

The following safety notes are primarily concerned with the general use of BestFlex gravity skate wheel conveyors.

7.2 General Information

LongReach have made every practicable attempt to eliminate and minimise the risk of injury which could be caused during the normal operation, installation, cleaning and maintenance of this plant, the associated risks are outlined in the appropriate Risk Assessment which is available on request. When using the conveyor the following safety practices must be adhered to help minimise the identified risks:

- ONLY authorised personnel should operate and service the conveyor
- When expanding, compacting and moving the conveyor keep hands clear of the side plates
- Keep loose items, including, hair, fingers, clothing, gloves, neckties and jewellery clear of moving parts
- Know design limits. Do not overload conveyor
- Replace worn and broken parts immediately
- Report ALL unsafe conditions and practices to your supervisor
- DO NOT walk, ride, sit or climb on conveyor

NOTE: ALL SAFETY FEATURES OF THE CONVEYOR MUST BE MAINTAINED IN SOUND WORKING CONDITION.

8 INSTALLATION

8.1 Shipping, Handling and Storage

For the transporting of a conveyor, the unit should be placed and strapped to a skid. When strapping conveyor to skid ensure conveyor is fully compacted. Place a minimum of one strap horizontally around the top of the conveyor (just below leg handles) to ensure conveyor can not accidentally expand. Place a minimum of one strap lengthways, vertically, over bottom leg cross tube to strap conveyor to skid. Lock all brake castors and apply shrink wrap around conveyor for protection.

The conveyors must be covered during shipping to prevent the ingress of water or dust.

The conveyor should be moved and stored compacted, and always by the handles provided.

8.2 Installation and unpacking

A forklift with sufficient capacity may be used to lift the conveyor. Extreme care must be taken to ensure that there is no damage to the underside of the conveyor from the forklift tynes.

SAFE WORK PROCEDURE



1. Ensure forklift has sufficient capacity to lift the conveyor (check manufacturers plate)
2. Ensure conveyor is securely strapped to skid
3. Remove all hold down restraints
4. Locate centre of gravity of conveyor
5. Carefully lift the conveyor via the skid and place onto ground
6. Remove conveyors wrapping and carefully remove straps
7. Carefully remove conveyor from skid onto ground using handles provided

POTENTIAL HAZARDS



1. Possible to fall from truck when loosening restrains
2. Possible to fall from truck when removing protective covering (tarp)
3. Possible to be crushed by moving conveyor
4. Possible to be struck by moving conveyor

Unpack and expand inspect the BestFlex conveyor prior to operation.

9 CONVEYOR OPERATION

9.1 Pre Operational Checks

Prior to operation of the conveyor it is important that a pre operational checklist is completed. The completion of a pre operational checklist will reduce the risk of injury to plant, environment and operator. The following is supplied as a guide, however as applicable owners, hirers, lessees or sellers should provide a safe work practise for this piece of equipment, including a pre-operational checklist.

Supervisor Checklist

- Ensure operators have been trained and completed a competency test in the use of BestFlex Conveyors
- Ensure Risk Assessment has been conducted on this piece of plant by OHS&W committee
- Ensure operators are wearing appropriate footwear, no loose clothing or jewellery, long hair is tied back and safety vests are worn, **gloves must not be worn**

Operator Checklist

- Check for conveyor and ensure it is free of dirt, debris and grease accumulation
- Inspect leg elevations and adjust as necessary to ensure smooth product flow
- Look for mechanical damage or worn components and replace as necessary
- Ensure the area is clear of obstructions

9.2 Conveyor operation – Expansion and Compaction

Ensure the area around the conveyor is clear of obstructions and debris.

SAFE WORK PROCEDURE



1. Notify immediate workmates that you are about to move the conveyor
2. Unlock the immediate castors
3. Grasp onto the conveyor handles on each side at both ends of the conveyor and pull until conveyor is expanded or compacted to required length
4. lock the castors before placing product onto conveyor

POTENTIAL HAZARDS



1. Possible to become entangled in rollers
2. Possible to get caught in between scissor
3. Possible to get caught between conveyor and objects
4. Possible to obtain injury if conveyor is ridden

9.3 Conveyor operation – Height Adjustment

Ensure the area around the conveyor is clear of obstructions and debris.

SAFE WORK PROCEDURE



1. Notify immediate workmates that you are about to move the conveyor
2. Ensure conveyor is fully expanded
3. Unscrew the adjustment knobs on the first leg set at **in-feed** end, lift the conveyor to required height and retighten the adjustment knobs
4. Unscrew the adjustment knobs on the first leg set at **discharge** end, lift the conveyor to required height and retighten the adjustment knobs
5. Adjust all intermediate legs as above to obtain correct flow
6. Compact the conveyor using leg handles and check for slopes and valleys between legs, readjust if required

POTENTIAL HAZARDS



1. Possible to get caught in between scissor
2. Possible to get caught between conveyor and objects
3. Possible to obtain injury if conveyor is ridden
4. Possible to obtain injury when lifting conveyor

9.4 Loading and unloading

The BestFlex conveyor is designed to enable operators to manually place cartons onto or remove cartons from the conveyor bed.

SAFE WORK PROCEDURE – LOADING ONTO CONVEYOR



1. Operator manually places carton or parcel onto conveyor using correct manually handling technique
2. Ensure freight is placed centrally onto conveyor
3. Small freight (e.g. envelopes, small cartons) should be placed on top of larger cartons
4. Ensure labels are facing in the required position

SAFE WORK PROCEDURE – UNLOADING FROM BELT



1. Operator to identify correct oncoming parcel via label
2. Operator manually removes carton or parcel from conveyor using correct manually handling technique
3. Ensure freight is placed centrally onto pallet or secondary conveyor (if applicable)
4. Ensure labels are facing in the required position

POTENTIAL HAZARDS



1. Possible to get caught in between scissor
2. Possible to get caught between conveyor and objects
3. Possible to get struck by objects on conveyor
4. Possible to obtain injury if conveyor is ridden
5. Possible to obtain injury when lifting conveyor

9.5 Troubleshooting

SYMPTOM	POSSIBLE CAUSE	RECOMMENDED ACTION
Conveyor does not open or roll smoothly	Castors are locked or clogged with debris Bolts and nuts have been over tightened Conveyor has suffered physical damage	Check castors and unlock or clean as necessary Check bolt tension and slacken off as required Check unit and replace damaged parts
Product stops on conveyor or does not flow smoothly	Leg elevations are out of height adjustment Rollers are jammed Conveyor has suffered physical damage	Re-adjust legs to the correct height settings Check and clean debris as necessary Check unit and replace damaged parts

10 SPARE PARTS

10.1 B/FR PARTS DIAGRAM

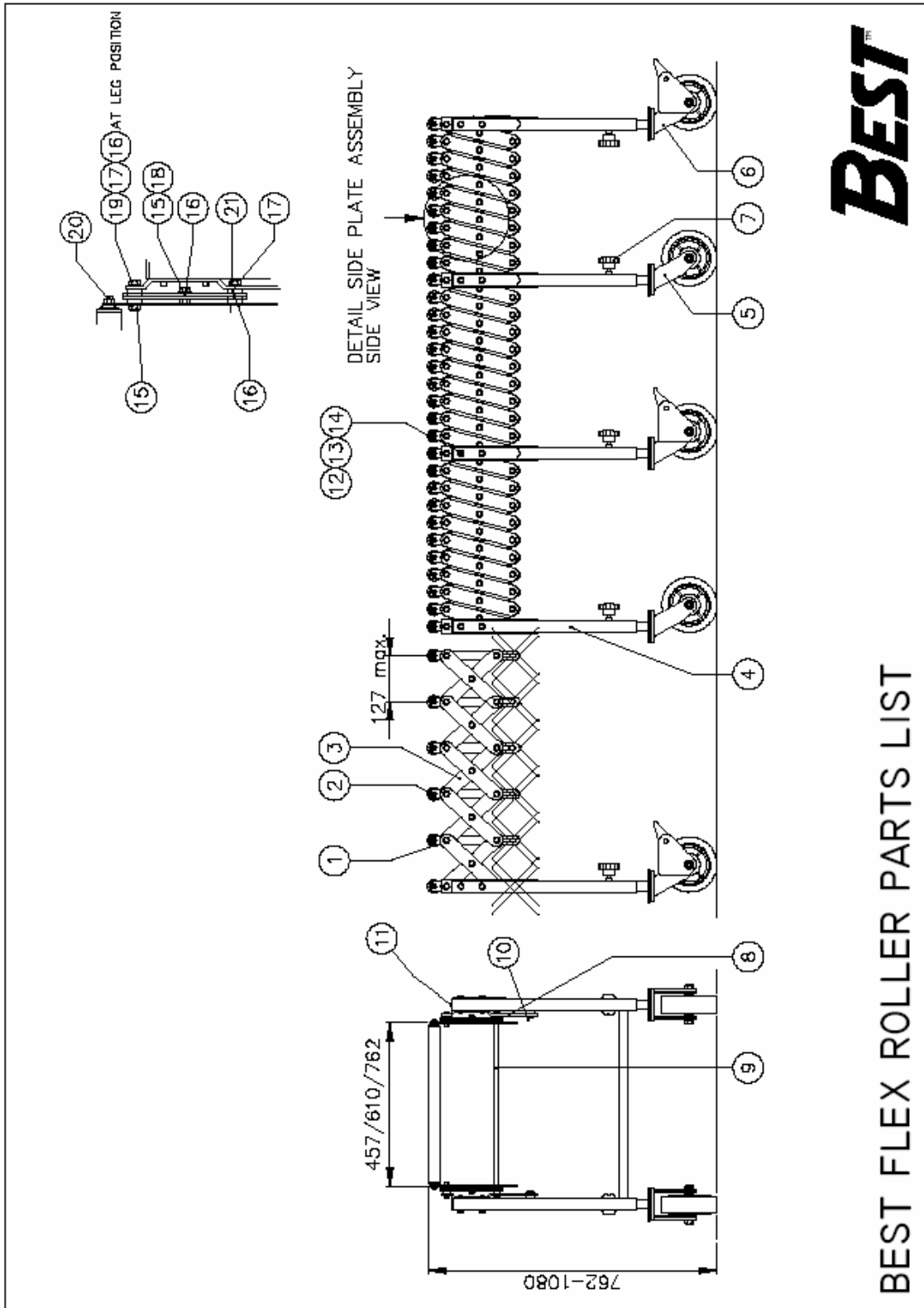

10.2 B/FR List

<u>ITEM</u>	<u>PART NO.</u>	<u>DESCRIPTION</u>
1.	100026	BFR Roller mounting bracket 127mm pitch
2.	100084 100088 100094	BFR Gravity Roller – 457mm BFR Gravity Roller – 610mm BFR Gravity Roller – 762mm
3.	100106	BFR/PF1.5 Side plate
4.	440016 440017 440018	BFR Leg Frame – 457mm BFR Leg Frame – 610mm BFR Leg Frame – 762mm
5.	110002	5" x 1¼" Non braked castor & stem
6.	110001	5" x 1¼" Braked castor & stem
7. UK	500118	Adjustment knob M10 UK style – 6 point
7. USA	12291	Adjustment knob 3/8 USA style – 8 point
8.	100043	BFR/PF Leg mounting bracket 127mm pitch
9.	100004 100005 100006	BFR Upper axle – 457mm BFR Upper axle – 610mm BFR Upper axle – 762mm
10.	500053	3/8" UNC x ½" Hex head screw
11.	100074	Leg cap 1¼" Square
12.	500052	3/8" UNC x 1 7/8" Hex head screw
13.	500104	3/8" Spring washer
14.	500101	Washer 1" x 3/8" x 5/64" Flat
15.	500029	5/15" UNC Nyloc half nut
16.	100127	Nylatron washer
17.	100123	Spacer/washer
18.	500004	5/16" UNC Shd. 3/8" Dia x 0.356"w bolt
19.	500006	5/16" UNC Shd. 3/8" Dia x 1.1"w bolt
20.	500030	5/16" Nyloc capped nut
21.	500005	5/16" UNC Shd. 3/8" Dia x 0.729"w bolt

11 OPTIONAL EXTRAS

11.1 Package Stop Assembly

The package stop assembly fits to the discharge end of the conveyor, and can be raised to prevent packages from falling off, or folded down when not in use.

<u>ITEM</u>	<u>PART NO.</u>	<u>DESCRIPTION</u>
1.	600011	Package Stop Assy. B/F 457mm
	600012	Package Stop Assy. B/F 610 mm
	600014	Package Stop Assy. B/F 762mm

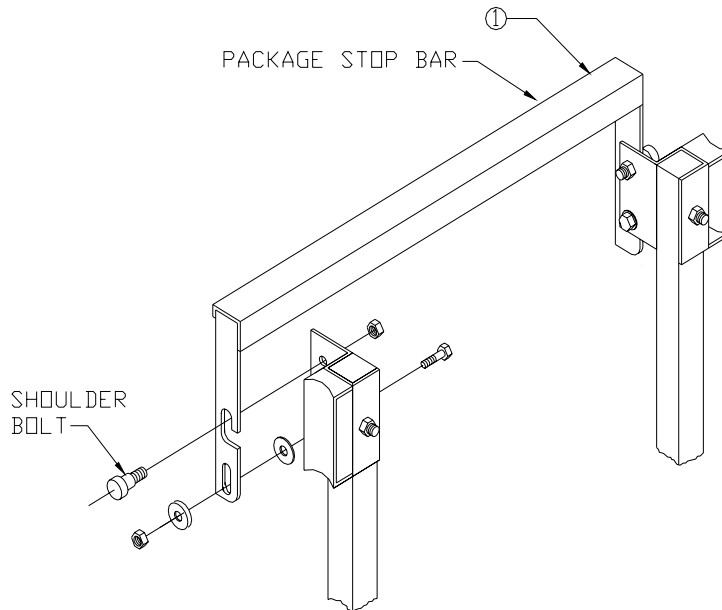

OPERATING INSTRUCTIONS

SAFE WORK PROCEDURE



1. Pull the package stop bar upward until it clears the shoulder bolts on each side of the conveyor
2. Rotate the package stop downward until it is parallel to the legs of the conveyor
3. To re-engage the package stop rotate the package stop upward and lock over the shoulder bolts
4. ensure package stop is secured into position correctly

POTENTIAL HAZARDS



1. Possible to get caught in between package stop and bracket
2. Possible to get caught between conveyor and objects

11.2 Leg Connect Assembly

The leg connect hook assembly enables 2 or more conveyors to be connected together quickly and easily, without the need for any tools.

<u>ITEM</u>	<u>PART NO.</u>	<u>DESCRIPTION</u>
1.	600010	Leg connect hook assembly
	600030	Leg connect assembly (without hooks, required for the connecting end of the second conveyor)

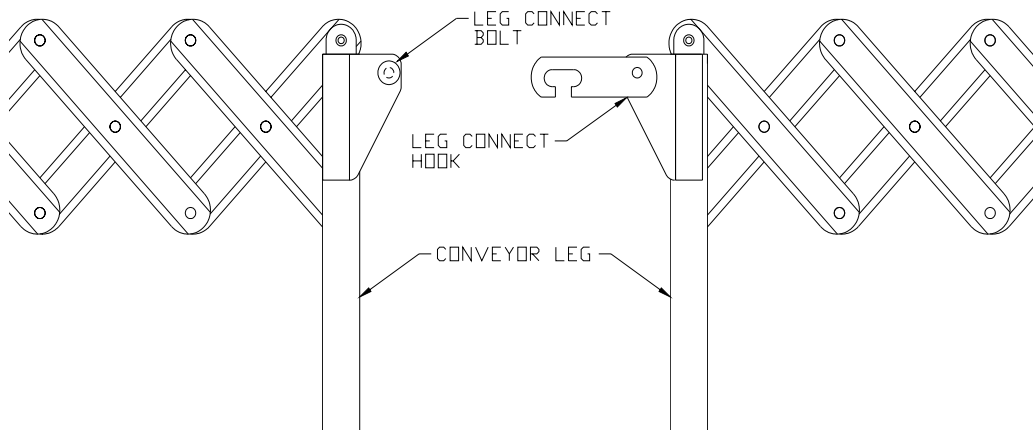

OPERATING INSTRUCTIONS

SAFE WORK PROCEDURE



1. Push the two conveyors leaving a small gap between them
2. Rotate the connection hooks on each side of conveyor and engage on to the shoulder bolts on the mating conveyor

POTENTIAL HAZARDS



1. Possible to get caught in between conveyors
2. Possible to get caught between connection hook and shoulder bolt